

TL5002 PULSE-WIDTH-MODULATION CONTROL CIRCUIT

SLVS304A – SEPTEMBER 2000 – REVISED AUGUST 2002

- Complete PWM Power Control
- 3.6-V to 40-V Operation
- Internal Undervoltage-Lockout Circuit
- Oscillator Frequency . . . 20 kHz to 500 kHz
- Variable Dead Time Provides Control Over Total Range
- Ideal Controller for DDR Memory Application
- Uncommitted Error Amplifier Inputs

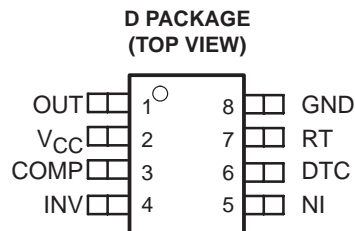

description

The TL5002 incorporates on a single monolithic chip all the functions required for a pulse-width-modulation (PWM) control circuit. Designed primarily for power-supply control, the TL5002 contains an error amplifier, a regulator, an oscillator, a PWM comparator with a dead-time-control input, undervoltage lockout (UVLO), and an open-collector output transistor.

The error-amplifier input common-mode voltage ranges from 0.9 V to 1.5 V. Dead-time control (DTC) can be set to provide 0% to 100% dead time by connecting an external resistor between DTC and GND. The oscillator frequency is set by terminating RT with an external resistor to GND. During low V_{CC} conditions, the UVLO circuit turns the output off until V_{CC} recovers to its normal operating range.

The TL5002 is characterized for operation from –40°C to 85°C.

AVAILABLE OPTIONS

T _A	SMALL OUTLINE (D)
–20°C to 85°C	TL5002CD
–40°C to 85°C	TL5002ID

The D package is available taped and reeled. Add the suffix R to the device type (e.g., TL5002CDR).

functional block diagram

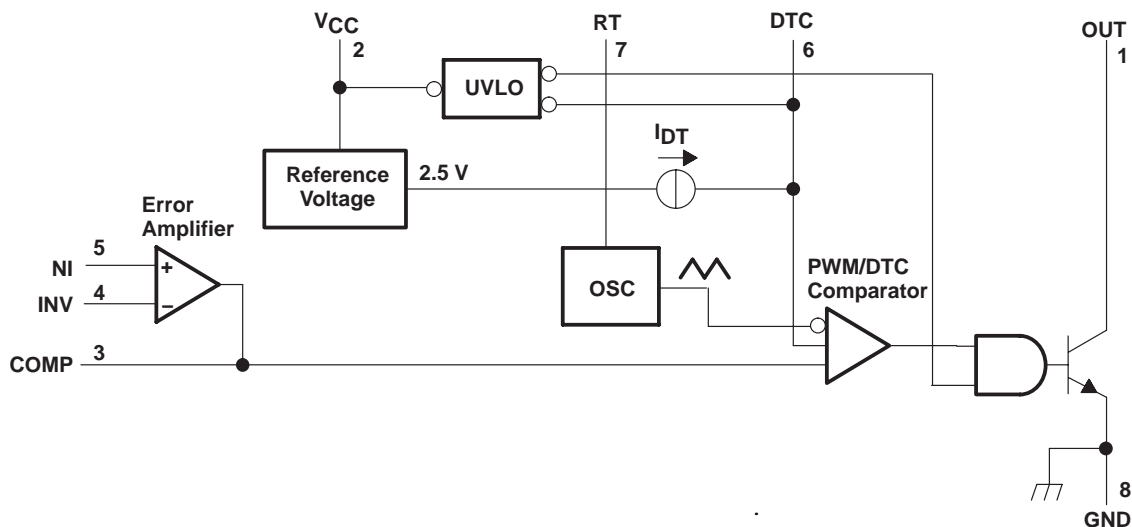

Please be aware that an important notice concerning availability, standard warranty, and use in critical applications of Texas Instruments semiconductor products and disclaimers thereto appears at the end of this data sheet.

PRODUCTION DATA information is current as of publication date. Products conform to specifications per the terms of Texas Instruments standard warranty. Production processing does not necessarily include testing of all parameters.

**TEXAS
INSTRUMENTS**

POST OFFICE BOX 655303 • DALLAS, TEXAS 75265

Copyright © 2002, Texas Instruments Incorporated

TL5002

PULSE-WIDTH-MODULATION CONTROL CIRCUIT

SLVS304A – SEPTEMBER 2000 – REVISED AUGUST 2002

detailed description

voltage reference

A 2.5-V regulator operating from V_{CC} is used to power the internal circuitry of the TL5002.

error amplifier

The error amplifier compares a sample of the dc-to-dc converter output voltage to an external reference voltage and generates an error signal for the PWM comparator. The dc-to-dc converter output voltage is set by selecting the error-amplifier gain (see Figure 1), using the following expression:

$$V_O = (1 + R1/R2) (1 \text{ V})$$

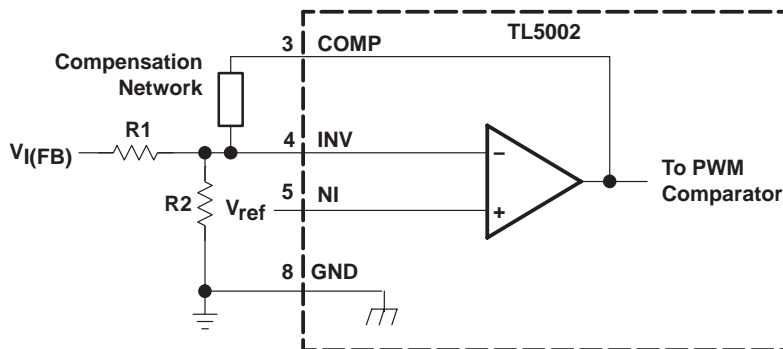

Figure 1. Error-Amplifier Gain Setting

The error-amplifier output is brought out as COMP for use in compensating the dc-to-dc converter control loop for stability. Because the amplifier can only source 45 μ A, the total dc load resistance should be 100 k Ω or more.

oscillator/PWM

The oscillator frequency (f_{OSC}) can be set between 20 kHz and 500 kHz by connecting a resistor between RT and GND. Acceptable resistor values range from 15 k Ω to 250 k Ω . The oscillator frequency can be determined by using the graph shown in Figure 5.

The oscillator output is a triangular wave with a minimum value of approximately 0.7 V and a maximum value of approximately 1.3 V. The PWM comparator compares the error-amplifier output voltage and the DTC input voltage to the triangular wave and turns the output transistor off whenever the triangular wave is greater than the lesser of the two inputs.

dead-time control (DTC)

DTC provides a means of limiting the output-switch duty cycle to a value less than 100%, which is critical for boost and flyback converters. A current source generates a reference current (I_{DTC}) at DTC that is nominally equal to the current at the oscillator timing terminal, RT. Connecting a resistor between DTC and GND generates a dead-time reference voltage (V_{DTC}), which the PWM/DTC comparator compares to the oscillator triangle wave as described in the previous section. Nominally, the maximum duty cycle is 0% when V_{DTC} is 0.7 V or less and 100% when V_{DTC} is 1.3 V or greater. Because the triangle wave amplitude is a function of frequency and the source impedance of RT is relatively high (1250 Ω), choosing R_{DTC} for a specific maximum duty cycle, D, is accomplished using the following equation and the voltage limits for the frequency in question as found in Figure 11 (V_{OSCmax} and V_{OSCmin} are the maximum and minimum oscillator levels):

dead-time control (DTC) (continued)

$$R_{DT} = (R_t + 1250) [D(V_{oscmax} - V_{oscmin}) + V_{oscmin}]$$

Where

R_{DT} and R_t are in ohms, D in decimal

Soft start can be implemented by paralleling the DTC resistor with a capacitor (C_{DT}) as shown in Figure 2. During soft start, the voltage at DTC is derived by the following equation:

$$V_{DT} \approx I_{DT}R_{DT} \left(1 - e^{-t/R_{DT}C_{DT}} \right)$$

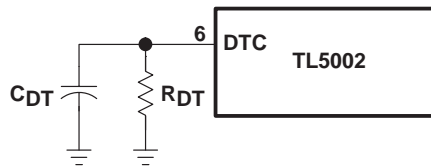

Figure 2. Soft-Start Circuit

If the dc-to-dc converter must be in regulation within a specified period of time, the time constant, $R_{DT}C_{DT}$, should be $t_0/3$ to $t_0/5$. The TL5002 remains off until $V_{DT} \approx 0.7$ V, the minimum ramp value. C_{DT} is discharged every time UVLO becomes active.

undervoltage-lockout (UVLO) protection

The undervoltage-lockout circuit turns the output transistor off whenever the supply voltage drops too low (approximately 3 V at 25°C) for proper operation. A hysteresis voltage of 200 mV eliminates false triggering on noise and chattering.

output transistor

The output of the TL5002 is an open-collector transistor with a maximum collector current rating of 21 mA and a voltage rating of 51 V. The output is turned on under the following conditions: the oscillator triangle wave is lower than both the DTC voltage and the error-amplifier output voltage, and the UVLO circuit is inactive.

TL5002

PULSE-WIDTH-MODULATION CONTROL CIRCUIT

SLVS304A – SEPTEMBER 2000 – REVISED AUGUST 2002

absolute maximum ratings over operating free-air temperature range (unless otherwise noted)†

Supply voltage, V_{CC} (see Note 1)	41 V
Amplifier input voltage, $V_{I(INV)}, V_{I(NI)}$	20 V
Output voltage, $V_{O, OUT}$	51 V
Output current, $I_{O, OUT}$	21 mA
Output peak current, $I_{O(peak), OUT}$	100 mA
Continuous total power dissipation	See Dissipation Rating Table
Operating ambient temperature range, T_A	-40°C to 85°C
Storage temperature range, T_{stg}	-65°C to 150°C
Lead temperature 1,6 mm (1/16 inch) from case for 10 seconds	260°C

† Stresses beyond those listed under “absolute maximum ratings” may cause permanent damage to the device. These are stress ratings only, and functional operation of the device at these or any other conditions beyond those indicated under “recommended operating conditions” is not implied. Exposure to absolute-maximum-rated conditions for extended periods may affect device reliability.

NOTE 1: All voltage values are with respect to network ground terminal.

DISSIPATION RATING TABLE

PACKAGE	$T_A \leq 25^\circ\text{C}$ POWER RATING	DERATING FACTOR ABOVE $T_A = 25^\circ\text{C}$	$T_A = 70^\circ\text{C}$ POWER RATING	$T_A = 85^\circ\text{C}$ POWER RATING	$T_A = 125^\circ\text{C}$ POWER RATING
D	725 mW	5.8 mW/°C	464 mW	377 mW	145 mW

recommended operating conditions

	MIN	MAX	UNIT
Supply voltage, V_{CC}	3.6	40	V
Amplifier input voltage, $V_{I(INV)}, V_{I(NI)}$	0.9	1.5	V
Output voltage, $V_{O, OUT}$		50	V
Output current, $I_{O, OUT}$		20	mA
COMP source current		45	μA
COMP dc load resistance	100		kΩ
Oscillator timing resistor, R_t	15	250	kΩ
Oscillator frequency, f_{osc}	20	500	kHz
Operating ambient temperature, T_A	-40	85	°C



TL5002 PULSE-WIDTH-MODULATION CONTROL CIRCUIT

SLVS304A – SEPTEMBER 2000 – REVISED AUGUST 2002

electrical characteristics over recommended operating free-air temperature range, $V_{CC} = 6\text{ V}$, $f_{osc} = 100\text{ kHz}$ (unless otherwise noted)

undervoltage lockout

PARAMETER	TEST CONDITIONS	TL5002C			UNIT
		MIN	TYP†	MAX	
Upper threshold voltage	$T_A = 25^\circ\text{C}$		3		V
Lower threshold voltage	$T_A = 25^\circ\text{C}$		2.8		V
Hysteresis	$T_A = 25^\circ\text{C}$	100	200		mV

† All typical values are at $T_A = 25^\circ\text{C}$.

oscillator

PARAMETER	TEST CONDITIONS	TL5002C			UNIT
		MIN	TYP†	MAX	
Frequency	$R_t = 100\text{ k}\Omega$		100		kHz
Standard deviation of frequency			15		kHz
Frequency change with voltage	$V_{CC} = 3.6\text{ V to }40\text{ V}$		1		kHz
Frequency change with temperature	$T_A = -40^\circ\text{C to }25^\circ\text{C}$	-4	-0.4	4	kHz
	$T_A = -20^\circ\text{C to }25^\circ\text{C}$	-4	-0.4	4	kHz
	$T_A = 25^\circ\text{C to }85^\circ\text{C}$	-4	-0.2	4	kHz
Voltage at RT			1		V

† All typical values are at $T_A = 25^\circ\text{C}$.

dead-time control

PARAMETER	TEST CONDITIONS	TL5002C			UNIT
		MIN	TYP†	MAX	
Output (source) current	TL5002 $V_{(DT)} = 1.5\text{ V}$	$0.9 \times I_{RT}^\ddagger$		$1.2 \times I_{RT}$	μA
Input threshold voltage	Duty cycle = 0%	0.5	0.7		V
	Duty cycle = 100%		1.3	1.5	

† All typical values are at $T_A = 25^\circ\text{C}$.

‡ Output source current at RT

error amplifier

PARAMETER	TEST CONDITIONS	TL5002C			UNIT
		MIN	TYP†	MAX	
Input voltage	$V_{CC} = 3.6\text{ V to }40\text{ V}$	0.3		1.5	V
Input bias current			-160	-500	nA
Output voltage swing	Positive	1.5	2.3		V
	Negative		0.3	0.4	V
Open-loop voltage amplification			80		dB
Unity-gain bandwidth			1.5		MHz
Output (sink) current	$V_{I(INV)} = 1.2\text{ V}, \text{ COMP} = 1\text{ V}$	100	600		μA
Output (source) current	$V_{I(INV)} = 0.8\text{ V}, \text{ COMP} = 1\text{ V}$	-45	-70		μA

† All typical values are at $T_A = 25^\circ\text{C}$.



TL5002 PULSE-WIDTH-MODULATION CONTROL CIRCUIT

SLVS304A – SEPTEMBER 2000 – REVISED AUGUST 2002

electrical characteristics over recommended operating free-air temperature range, $V_{CC} = 6\text{ V}$, $f_{osc} = 100\text{ kHz}$ (unless otherwise noted) (continued)

output

PARAMETER	TEST CONDITIONS	TL5002C			UNIT
		MIN	TYP†	MAX	
Output saturation voltage	$I_O = 10\text{ mA}$		1.5	2	V
Off-state current	$V_O = 50\text{ V}, V_{CC} = 0$			10	μA
	$V_O = 50\text{ V}$			10	
Short-circuit output current	$V_O = 6\text{ V}$		40		mA

† All typical values are at $T_A = 25^\circ\text{C}$.

total device

PARAMETER		TEST CONDITIONS	TL5002C			UNIT
			MIN	TYP†	MAX	
Standby supply current	Off state			1	1.5	mA
Average supply current		$R_t = 100\text{ k}\Omega$		1.4	2.1	mA

† All typical values are at $T_A = 25^\circ\text{C}$.

PARAMETER MEASUREMENT INFORMATION

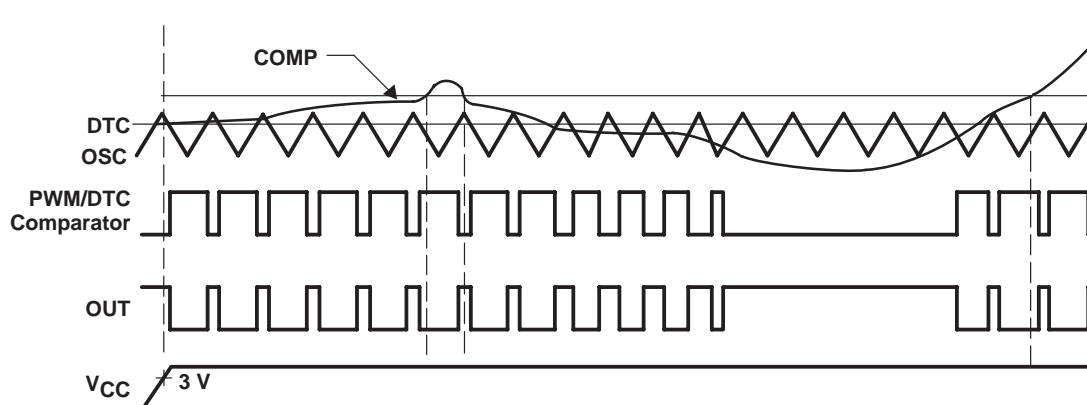

Figure 3. PWM Timing Diagram

TYPICAL CHARACTERISTICS

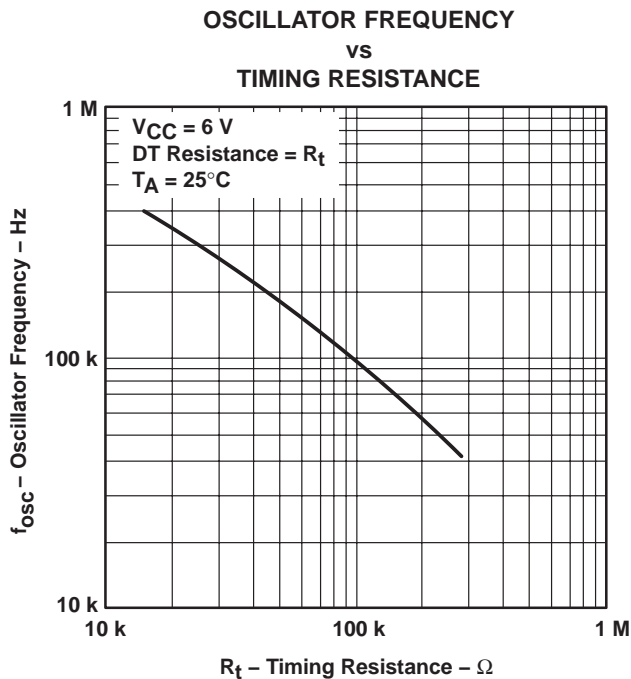

Figure 4

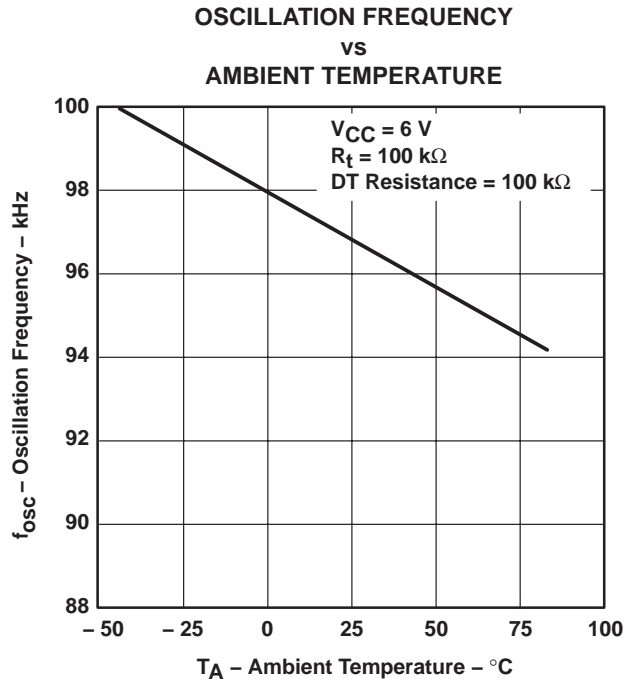

Figure 5

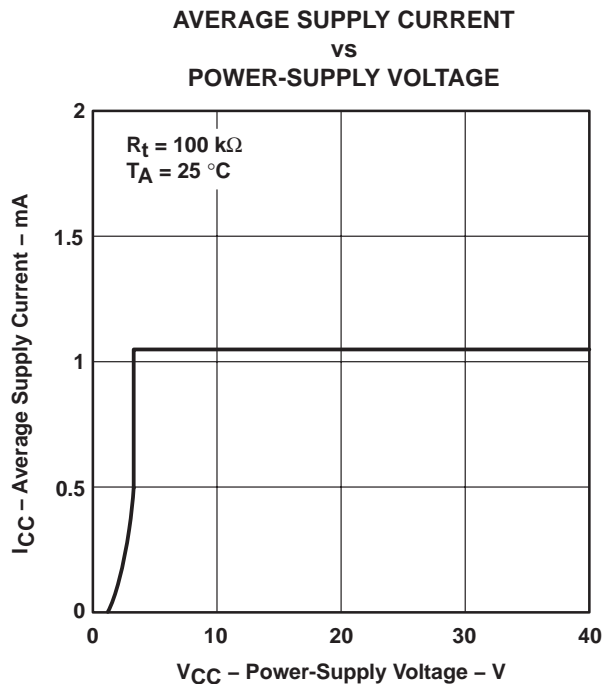

Figure 6

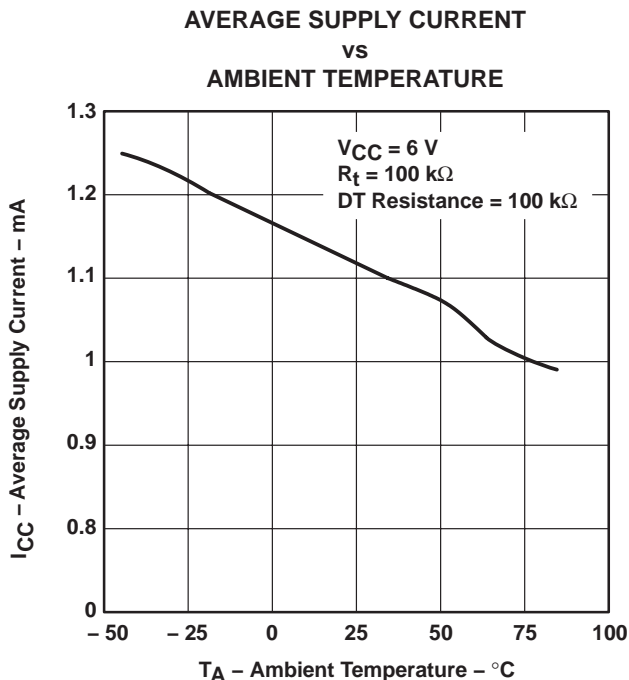

Figure 7

TL5002 PULSE-WIDTH-MODULATION CONTROL CIRCUIT

SLVS304A – SEPTEMBER 2000 – REVISED AUGUST 2002

TYPICAL CHARACTERISTICS

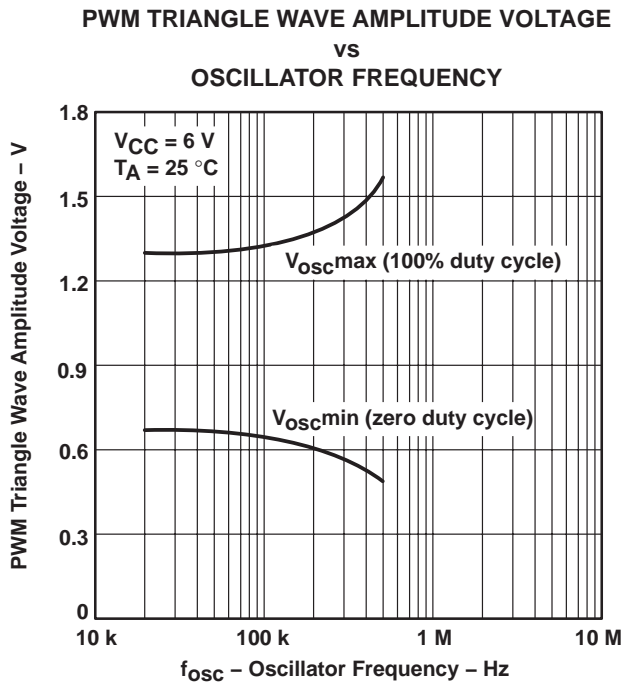

Figure 8

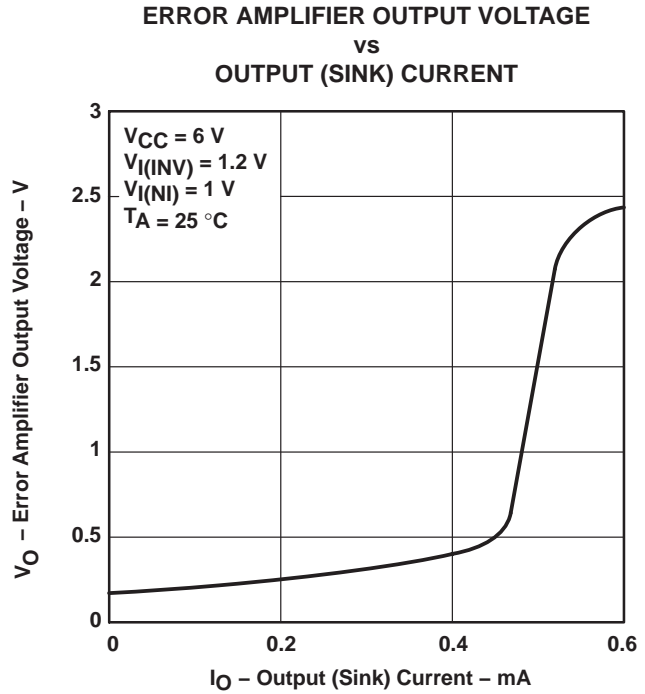

Figure 9

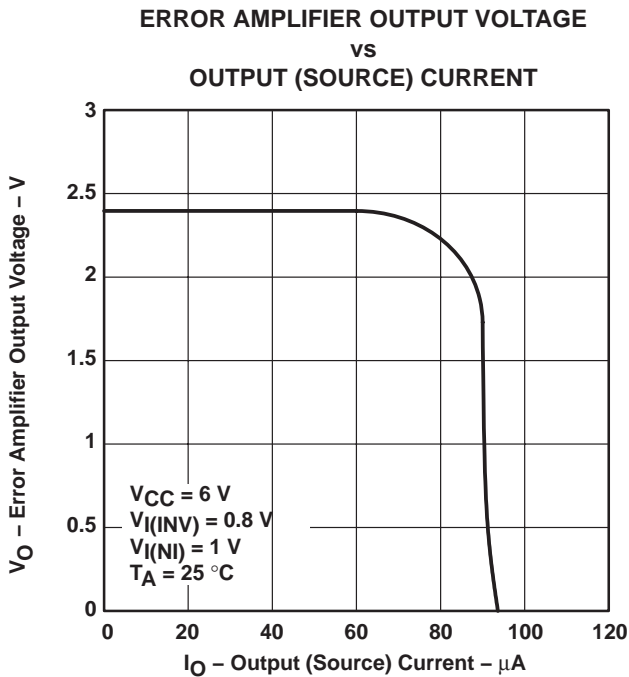

Figure 10

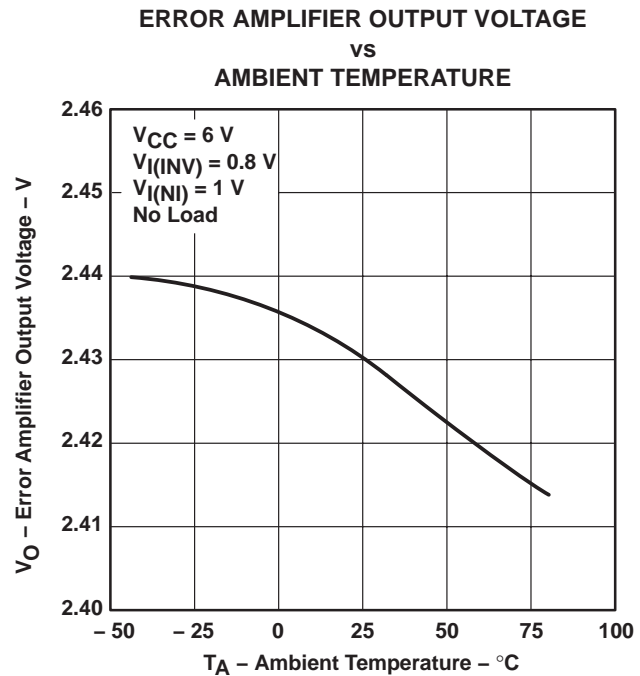

Figure 11

TYPICAL CHARACTERISTICS

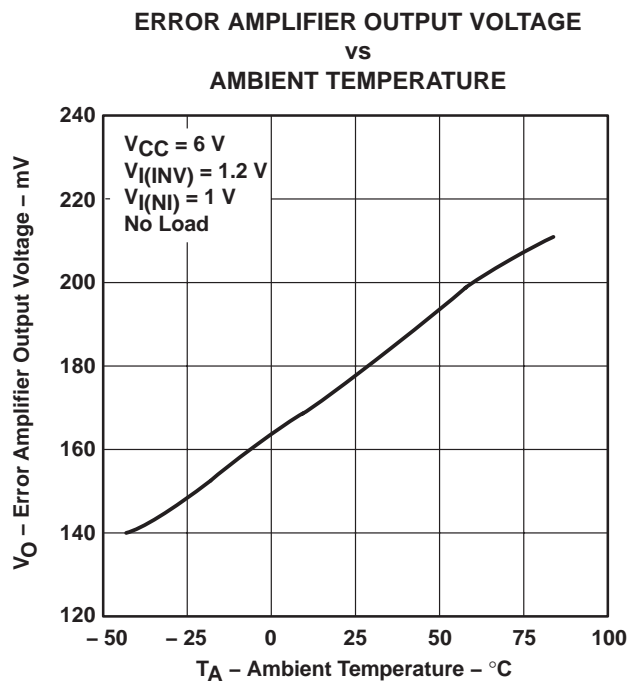

Figure 12

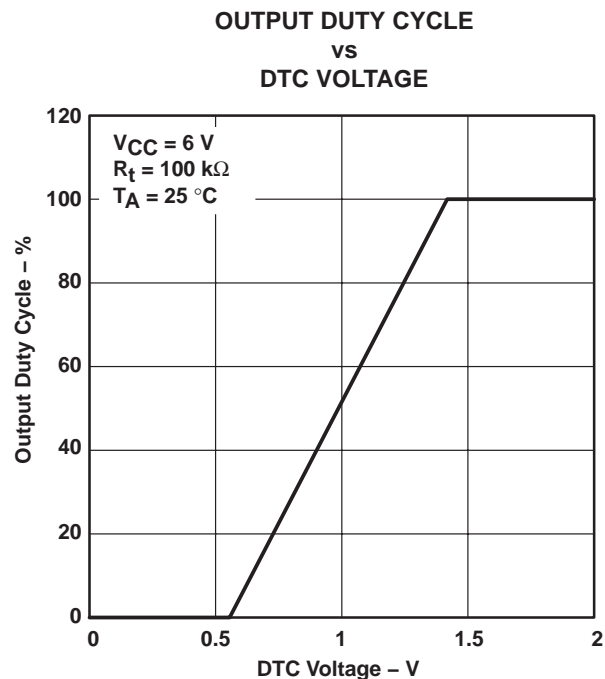

Figure 13

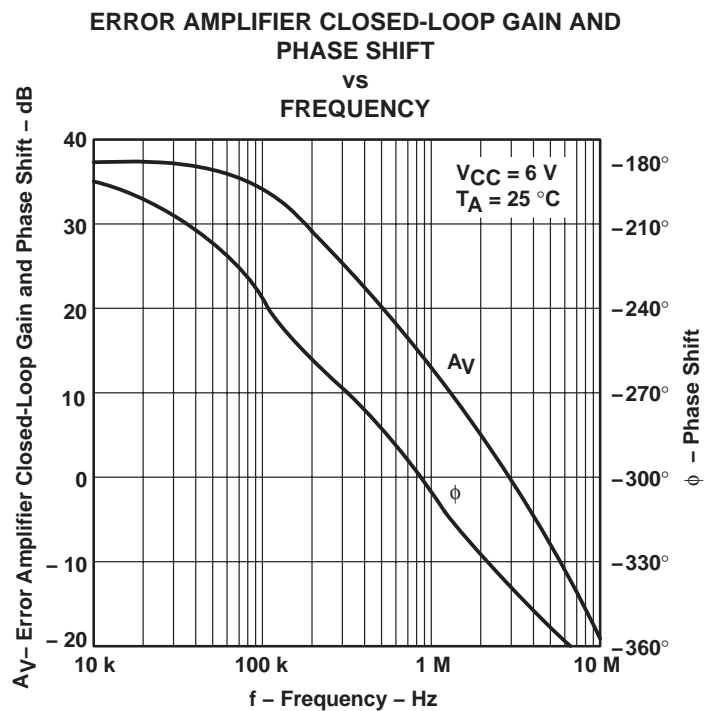

Figure 14

TL5002
PULSE-WIDTH-MODULATION CONTROL CIRCUIT

SLVS304A – SEPTEMBER 2000 – REVISED AUGUST 2002

TYPICAL CHARACTERISTICS

**DTC OUTPUT CURRENT
 vs
 RT OUTPUT CURRENT**

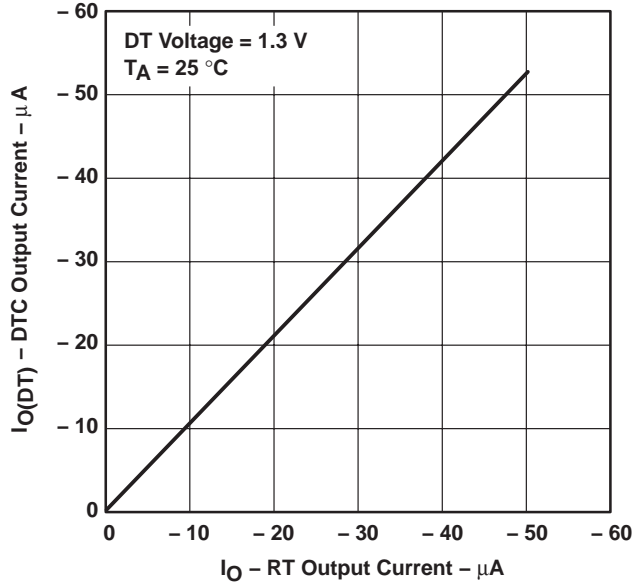

Figure 15

**OUTPUT SATURATION VOLTAGE
 vs
 OUTPUT (SINK) CURRENT**

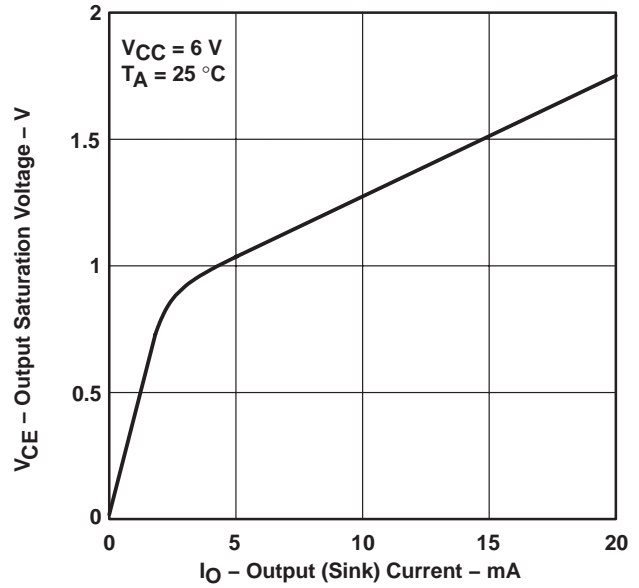

Figure 16

APPLICATION INFORMATION

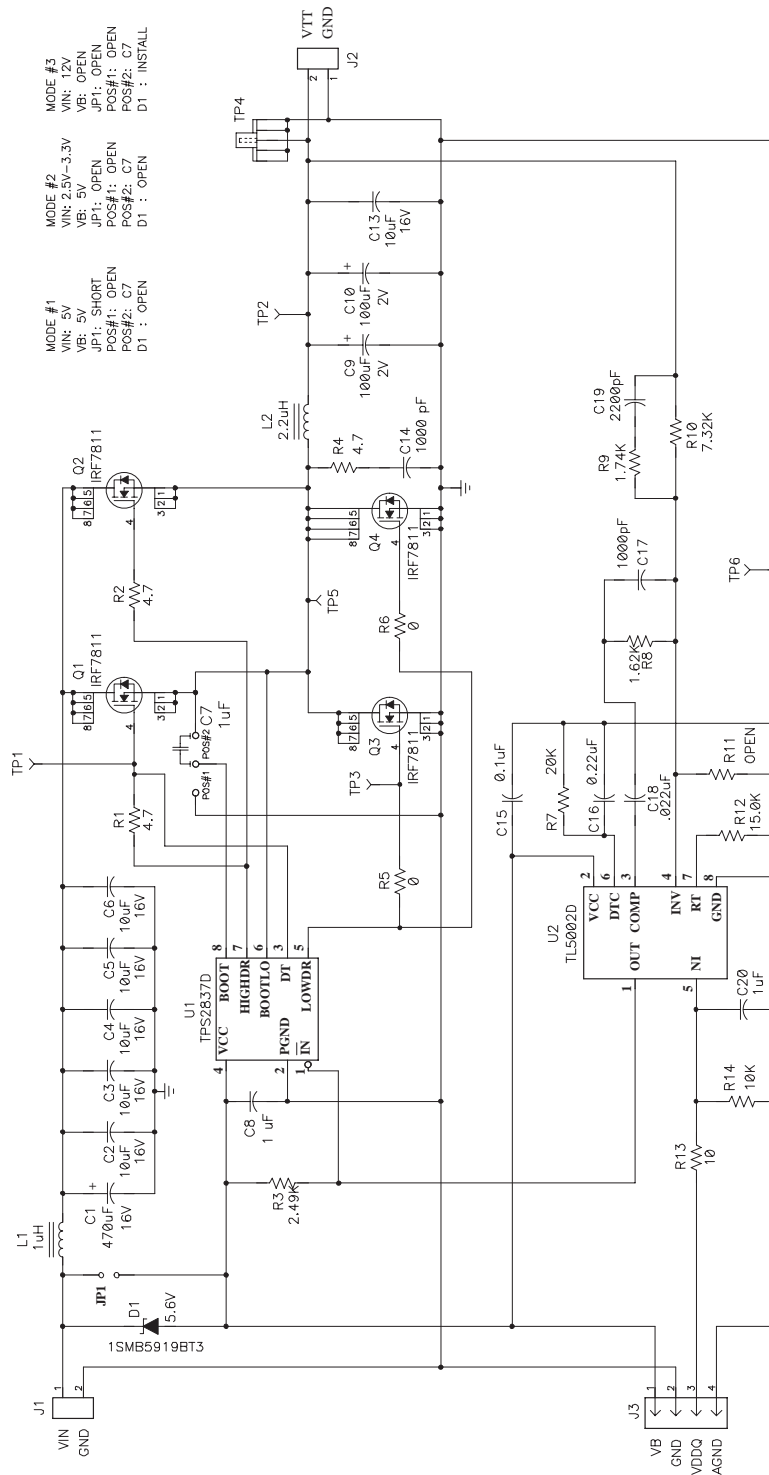

Figure 17. DDR1 Application

TL5002 PULSE-WIDTH-MODULATION CONTROL CIRCUIT

SLVS304A – SEPTEMBER 2000 – REVISED AUGUST 2002

APPLICATION INFORMATION

PARTIAL BILL OF MATERIALS

QUANTITY	REF DES	PART NUMBER	DESCRIPTION	MANUFACTURER	SIZE
1	C1	UUD1C471MNR1GS	Capacitor, aluminum	Nichicon	0.327 x 0.327
6	C2 – C6, C13	EMK325BJ106MN–B	Capacitor, ceramic	Taiyo Yuden	1210
3	C7, C8, C20	GRM40X7R105K16PT	Capacitor, ceramic, jumper	Murata	805
2	C9, C10	EEF–CD0D101R	Capacitor, aluminum	Panasonic	7343
1	C14	08055A102JAT2A	Capacitor, ceramic	AVX	805
1	C15	GRM39X7R104K016D	Capacitor, ceramic	Murata	603
1	C16	NMC0805X7R224K16TR	Capacitor, ceramic	NIP	603
1	C17	VJ0603Y222KXANT	Capacitor, ceramic	Murata	603
1	C18	C0603C223J3RACTU	Capacitor, ceramic	Kemet	603
1	C19	GRM39X7R223K16	Capacitor, ceramic	Murata	603
1	D1	1SMB5919BT3	Diode, zener, 5.6 V	On Semi	SMB
2	J1, J2	ED1609	Terminal block, 2-pin	OST	
1	J3	PTC36SAAN	Header, 4-pin	Sullins	
1	JP1	PTC36SAAN	Header, 2-pin	Sullins	
1	L1	UP2B–1R0	Inductor, SMT	Coiltronics	0.55 x 0.41
1	L2	UP4B–2R2	Inductor, SMT	Coiltronics	
4	Q1 – Q4	IRF7811	MOSFET, N–ch, 30 V	IR	SO8
3	R1, R2, R4	Std	Resistor, chip, 4.7 Ω	Std	603
1	R3	Std	Resistor, chip, 2.49 K Ω	Std	603
2	R5, R6	Std	Resistor, chip, 0 Ω	Std	603
1	R7	Std	Resistor, chip, 20 K Ω	Std	603
1	R8	Std	Resistor, chip, 162 K Ω	Std	603
1	R9	Std	Resistor, chip, 1.74 K Ω	Std	603
1	R10	Std	Resistor, chip, 7.32 K Ω	Std	603
1	R11	Std	Open	Std	603
1	R12	Std	Resistor, chip, 15 K Ω	Std	603
1	R13	Std	Resistor, chip, 10 Ω	Std	603
1	R14	Std	Resistor, chip, 10 K Ω	Std	603
4	TP1 – TP3, TP5	240-345	Test point, red, 1 mm	Farnell	0.038
1	TP4	131-4244-00 or 131-5031-00	Adaptor, 3.5 mm probe	Tektronix	0.200
1	TP6	1045-3-17-15-30-14-02-0	Post, wirewrap	Mill-Max	0.043
1	U1	TPS2837D	IC, MOSFET driver	Texas Instruments	SO8
1	U2	TL5002D	IC, low-cost PMW	Texas Instruments	SO8



POST OFFICE BOX 655303 • DALLAS, TEXAS 75265

MECHANICAL DATA

D (R-PDSO-G)**

PLASTIC SMALL-OUTLINE PACKAGE

14 PIN SHOWN

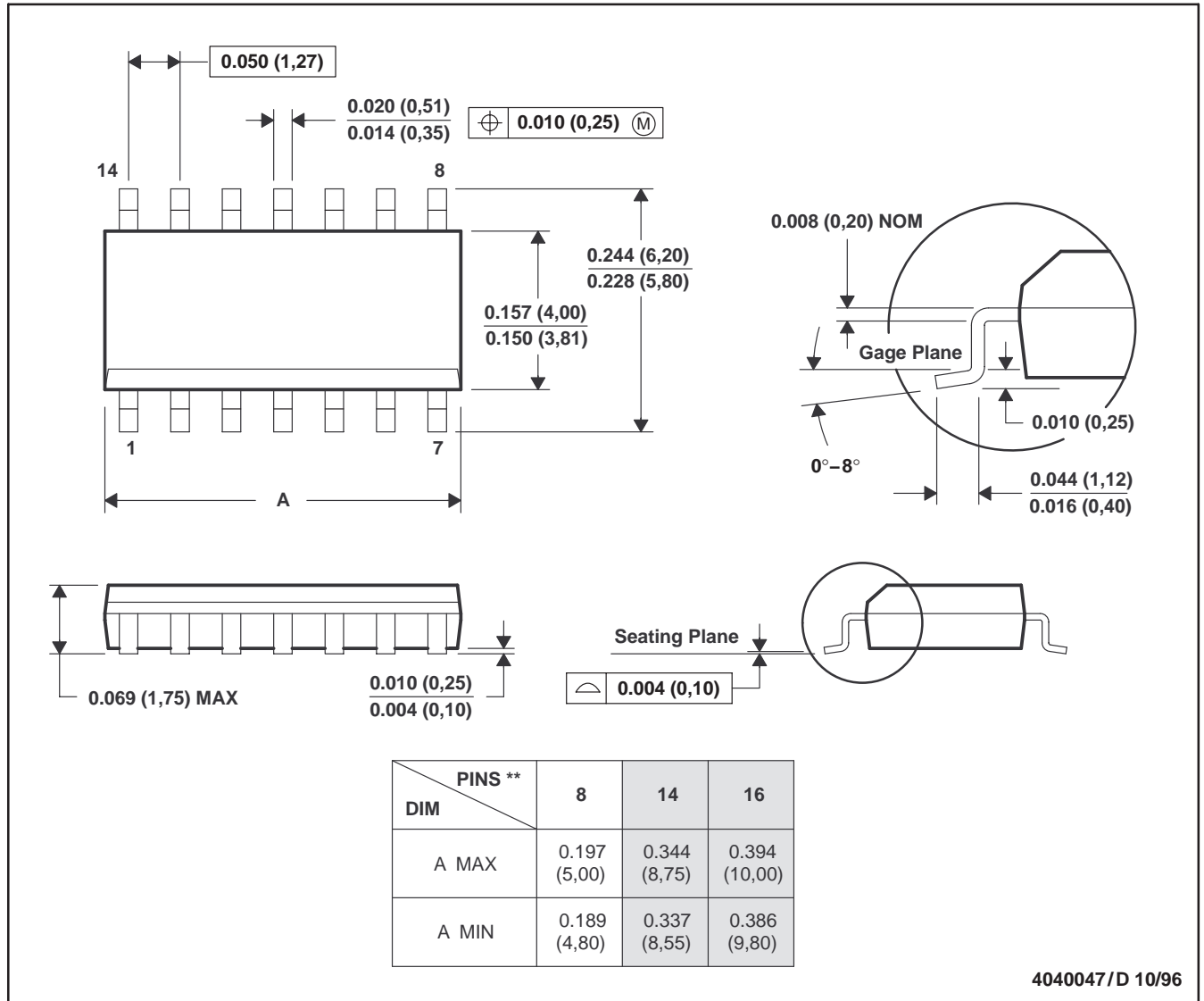

- NOTES: A. All linear dimensions are in inches (millimeters).
 B. This drawing is subject to change without notice.
 C. Body dimensions do not include mold flash or protrusion, not to exceed 0.006 (0,15).
 D. Falls within JEDEC MS-012

IMPORTANT NOTICE

Texas Instruments Incorporated and its subsidiaries (TI) reserve the right to make corrections, modifications, enhancements, improvements, and other changes to its products and services at any time and to discontinue any product or service without notice. Customers should obtain the latest relevant information before placing orders and should verify that such information is current and complete. All products are sold subject to TI's terms and conditions of sale supplied at the time of order acknowledgment.

TI warrants performance of its hardware products to the specifications applicable at the time of sale in accordance with TI's standard warranty. Testing and other quality control techniques are used to the extent TI deems necessary to support this warranty. Except where mandated by government requirements, testing of all parameters of each product is not necessarily performed.

TI assumes no liability for applications assistance or customer product design. Customers are responsible for their products and applications using TI components. To minimize the risks associated with customer products and applications, customers should provide adequate design and operating safeguards.

TI does not warrant or represent that any license, either express or implied, is granted under any TI patent right, copyright, mask work right, or other TI intellectual property right relating to any combination, machine, or process in which TI products or services are used. Information published by TI regarding third-party products or services does not constitute a license from TI to use such products or services or a warranty or endorsement thereof. Use of such information may require a license from a third party under the patents or other intellectual property of the third party, or a license from TI under the patents or other intellectual property of TI.

Reproduction of TI information in TI data books or data sheets is permissible only if reproduction is without alteration and is accompanied by all associated warranties, conditions, limitations, and notices. Reproduction of this information with alteration is an unfair and deceptive business practice. TI is not responsible or liable for such altered documentation. Information of third parties may be subject to additional restrictions.

Resale of TI products or services with statements different from or beyond the parameters stated by TI for that product or service voids all express and any implied warranties for the associated TI product or service and is an unfair and deceptive business practice. TI is not responsible or liable for any such statements.

TI products are not authorized for use in safety-critical applications (such as life support) where a failure of the TI product would reasonably be expected to cause severe personal injury or death, unless officers of the parties have executed an agreement specifically governing such use. Buyers represent that they have all necessary expertise in the safety and regulatory ramifications of their applications, and acknowledge and agree that they are solely responsible for all legal, regulatory and safety-related requirements concerning their products and any use of TI products in such safety-critical applications, notwithstanding any applications-related information or support that may be provided by TI. Further, Buyers must fully indemnify TI and its representatives against any damages arising out of the use of TI products in such safety-critical applications.

TI products are neither designed nor intended for use in military/aerospace applications or environments unless the TI products are specifically designated by TI as military-grade or "enhanced plastic." Only products designated by TI as military-grade meet military specifications. Buyers acknowledge and agree that any such use of TI products which TI has not designated as military-grade is solely at the Buyer's risk, and that they are solely responsible for compliance with all legal and regulatory requirements in connection with such use.

TI products are neither designed nor intended for use in automotive applications or environments unless the specific TI products are designated by TI as compliant with ISO/TS 16949 requirements. Buyers acknowledge and agree that, if they use any non-designated products in automotive applications, TI will not be responsible for any failure to meet such requirements.

Following are URLs where you can obtain information on other Texas Instruments products and application solutions:

Products

Amplifiers	amplifier.ti.com
Data Converters	dataconverter.ti.com
DSP	dsp.ti.com
Clocks and Timers	www.ti.com/clocks
Interface	interface.ti.com
Logic	logic.ti.com
Power Mgmt	power.ti.com
Microcontrollers	microcontroller.ti.com
RFID	www.ti-rfid.com
RF/IF and ZigBee® Solutions	www.ti.com/lprf

Applications

Audio	www.ti.com/audio
Automotive	www.ti.com/automotive
Broadband	www.ti.com/broadband
Digital Control	www.ti.com/digitalcontrol
Medical	www.ti.com/medical
Military	www.ti.com/military
Optical Networking	www.ti.com/opticalnetwork
Security	www.ti.com/security
Telephony	www.ti.com/telephony
Video & Imaging	www.ti.com/video
Wireless	www.ti.com/wireless

Mailing Address: Texas Instruments, Post Office Box 655303, Dallas, Texas 75265
Copyright © 2008, Texas Instruments Incorporated